

ComIoT 04

802.11b/g/n 无线路由核心模组

- 低功耗
- 高通方案
- 可开放开发资料
- 300M 无线传输速率
- 支持 OpenWRT 方案

1. 产品介绍

ComIoT 04模块是由深圳星恒讯科技有限公司研发并生产的一款无线路由核心模组。它是一个高集成的小型 802.11 b/g/n Wi-Fi网关模组。ComIoT 04模组将Wi-Fi功能、网口、串口、USB及路由系统集成在一个低成本的封装中，只需要搭建简单的几个外部电路就可以将模块完美应用起来。

该模块基于高通的QCA9531，集成了 802.11n 2x2 MAC/BB/radio 以及内部 PA 和 LNA。它支持 802.11n, 20 MHz 和 40 MHz 信道分别高达 144 Mbps 和 300 Mbps，以及 IEEE 802.11b/g 数据速率。模块采用OpenWRT的操作系统，同时支持AP模式和客户端模式，包含各类应用软件，以减少客户的开发和设计工作。

硬件架构如下图所示：

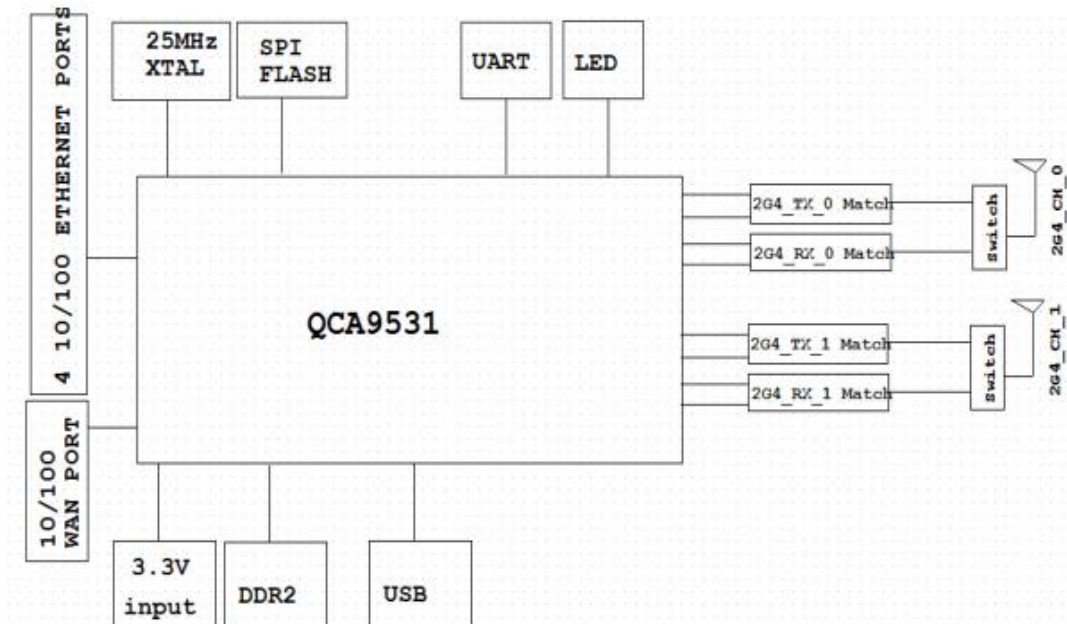

硬件框图设计

1.1 协议规范

模块支持以下协议规范:

- IEEE Std. 802.11b
- IEEE Std. 802.11g
- IEEE Std. 802.11n

1.2 模块信息

主芯片	QCA9531
射频频率	2.40~2.4835GHz
Wi-Fi 协议	802.11b/g/n(2X2)
调制解调	11b: DBPSK, DQPSK and CCK and DSSS 11g: BPSK, QPSK, 16QAM, 64QAM and OFDM 11n: MCS0~15 OFDM
理论带宽	11b:1, 2, 5.5 and 11Mbps 11g:6, 9, 12, 18, 24, 36, 48 and 54 Mbps 11n: MCS0~15, up to 300Mbps
排针	60pin CONN, 1.27mm pitch。
主要接口	Ethernet, UART, USB
PCB	4 层
尺寸	48.4mm(W)*26mm(L)*1.0mm(T)
天线	标准 ipex
工作温度	-10°C to +70°C
存储温度	-40°C to +150°C
工作电压	3.3V +/-10%
平均功耗	1.5W
GPIO 输出电压	2.5 V +/-10%

2. 结构尺寸

2.1 外观

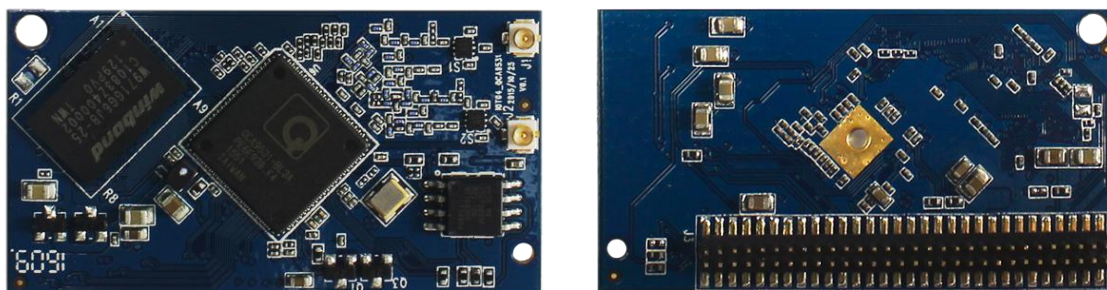

2.2 尺寸

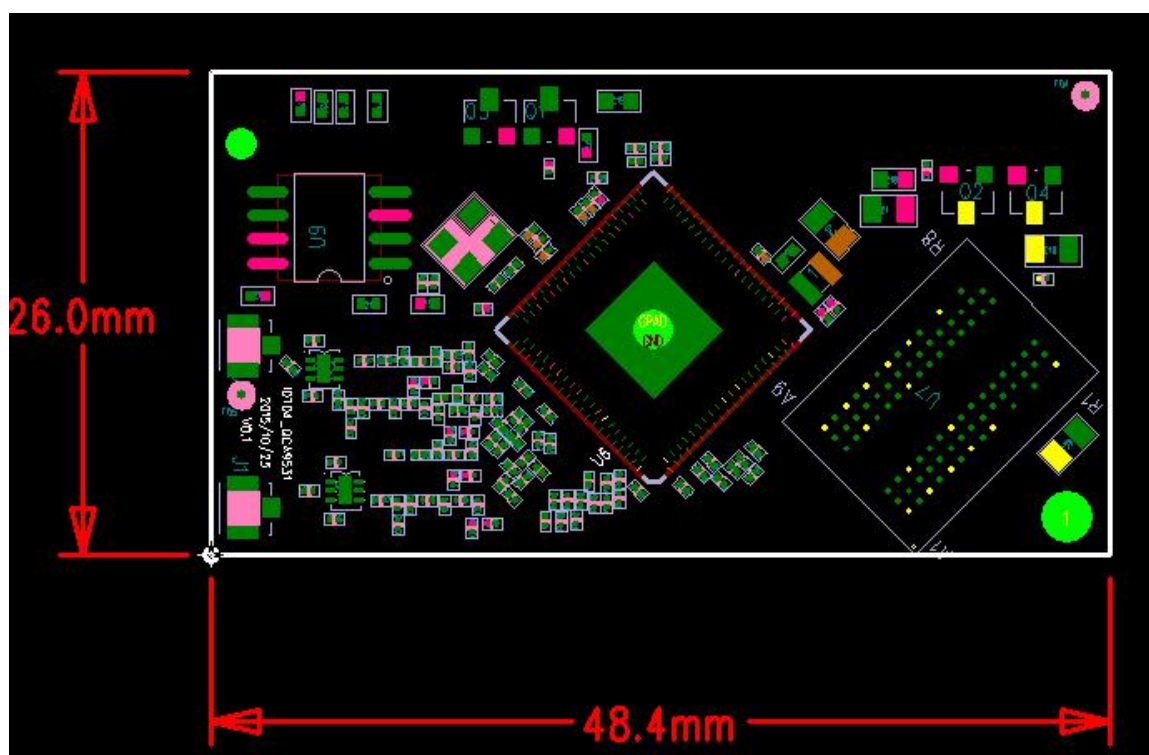

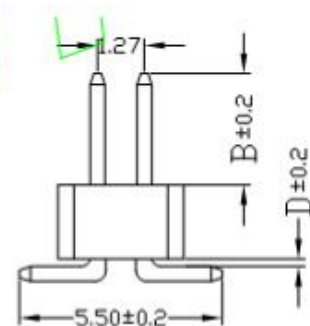
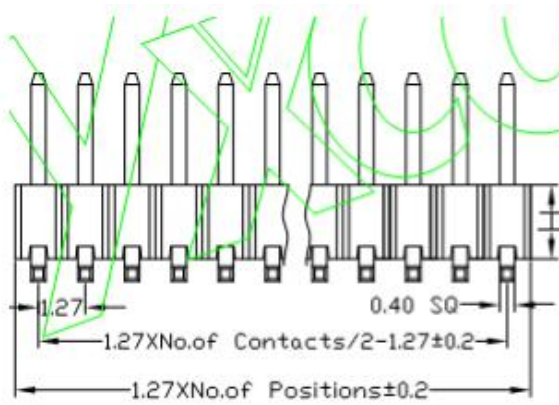
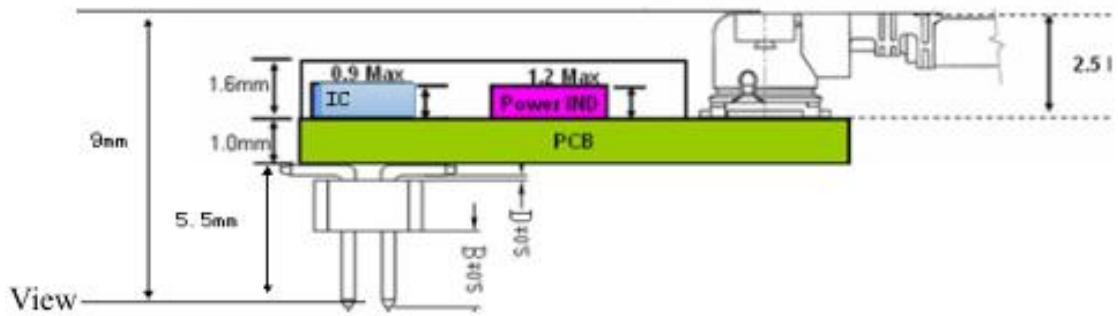
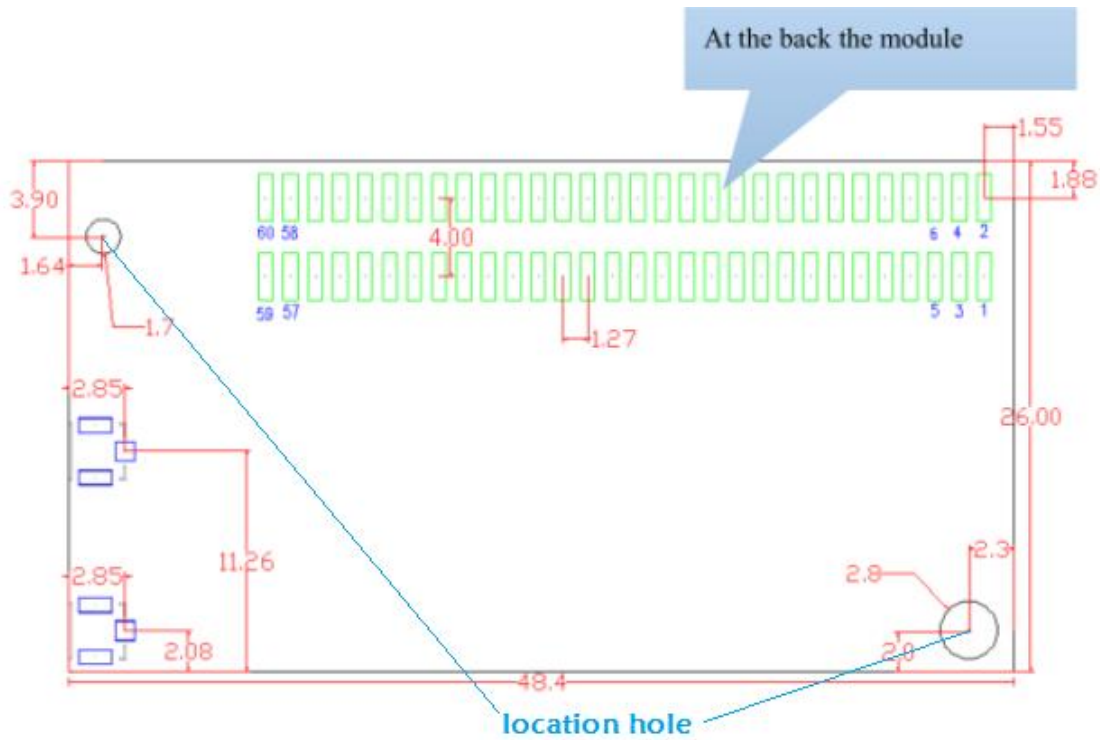

Dimension antitheses list

ITEM	D	B	H
Standard	0 1.2 1.8 3.0 4.0 1.6 2.0 2.54		
...			

2.3 引脚定义

引脚	名称	描述
1	GND	GROUND
2	GND	GROUND
3	LED_LINK_4(GPIO_11)	LAN_PORT3_LED
4	LAN_PORT2_RX+	Ethernet port
5	LED_LINK_3 (GPIO_14)	LAN_PORT2_LED
6	LAN_PORT2_RX-	Ethernet por
7	LED_LINK_2 (GPIO_15)	LAN_PORT1_LED
8	LAN_PORT2_TX+	Ethernet port
9	GND	GROUND
10	LAN_PORT2_TX-	Ethernet port
11	LAN_PORT3_TX+	Ethernet port
12	GND	GROUND
13	LAN_PORT3_TX-	Ethernet port
14	LAN_PORT1_TX+	Ethernet port
15	LAN_PORT3_RX+	Ethernet port
16	LAN_PORT1_TX-	Ethernet port
17	LAN_PORT3_RX-	Ethernet port
18	LAN_PORT1_RX+	Ethernet port
19	VDD_3.3V	3.3V input 1000mA, recommended voltage 3.3V
20	LAN_PORT1_RX-	Ethernet por
21	VDD_3.3V	3.3V input 1000mA, recommended voltage 3.3V
22	GND	GROUND
23	GPIO_0	GPIO
24	WAN_PORT_RX+	Ethernet port
25	GPIO_1	GPIO
26	WAN_PORT_RX-	Ethernet port
27	GPIO_2	GPIO
28	WAN_PORT_TX+	Ethernet port
29	NC	NC
30	WAN_PORT_TX-	Ethernet port
31	NC	NC
32	LAN_PORT0_RX+	Ethernet port
33	NC	NC
34	LAN_PORT0_RX-	Ethernet port
35	USB +	USB signal,
36	LAN_PORT0_TX+	Ethernet port
37	USB -	USB signal
38	LAN_PORT0_TX-	Ethernet port
39	SYSTEM_LED(GPIO_13)	SYSTEM LED
40	GND	GROUND
41	VDD_2.5V OUTPUT	IO voltage output

42	VDD_2.0V OUTPUT	Power supply output for peripheral network transformer
43	RESET	external power on reset , it has an internal 10 K pull up resistance,the external pull low effective.
44	VDD_2.0V OUTPUT	Power supply output for peripheral network transformer
45	JUMPSTART (GPIO_17)	KEY_INPUT to start WPS function, it has an internal 10 K pull-up resistance,the external pull low effective.
46	GND	GROUND
47	GND	GROUND
48	SPI_MISO	SPI serial interface
49	VDD_3.3V	3.3V input 1000mA, recommended voltage 3.3V
50	SPI_CLK	SPI serial interface
51	VDD_3.3V	3.3V input 1000mA, recommended voltage 3.3V
52	SPI_MOSI	SPI serial interface
53	WAN_LED (GPIO_4)	WLAN LED
54	LED_LINK_1 (GPIO_16)	LAN_PORT0_LED
55	NC	NC
56	WLAN_LED (GPIO_12)	Wireless LED
57	UART_RX	Serial data in
58	UART_TX	Serial data out
59	GND	GROUND
60	GND	GROUND

3. 射频规格

3.1 802.11b 模式

项目	规格				
协议	IEEE802.11b				
模式	DSSS / CCK				
频段	CH1 to CH13				
速率	1, 2, 5.5, 11Mbps				
TX Characteristics	Min.	Typ.	Max.	Unit	
2. Power Levels(Calibrated)					
1) 18dBm Target	16	18	20	dBm	
3. Spectrum Mask @ target power					
1) fc +/-11MHz to +/-22MHz	-	-	-30	dBr	
2) fc > +/-22MHz	-	-	-50	dBr	
4. Frequency Error	-25	0	+25	ppm	
RX Characteristics	Min.	Typ.	Max.	Unit	
5. Minimum Input Level Sensitivity					

1) 1Mbps (FER \leq 8%)	-	-	-96	dBm	
2) 2Mbps (FER \leq 8%)	-	-	-93	dBm	
3) 5.5Mbps (FER \leq 8%)	-	-	-91	dBm	
4) 11Mbps (FER \leq 8%)	-	-91	-90	dBm	
6. Maximum Input Level (FER \leq 8%)	-20	-10	-	dBm	

3.2 802.11g 模式

项目	规格				
协议	IEEE802.11g				
模式	OFDM				
频段	CH1 to CH13				
速率	6, 9, 12, 18, 24, 36, 48, 54Mbps				
TX Characteristics	Min.	Typ.	Max.	Unit	
2. Power Levels					
1) 18dBm Target @6Mbps	16	18	20	dBm	
2) 15dBm Target @54Mbps	13	15	17	dBm	
3. Spectrum Mask @ target power					
1) at fc +/- 11MHz	-	-	-20	dBr	
2) at fc +/- 20MHz	-	-	-28	dBr	
3) at fc > +/-30MHz	-	-	-40	dBr	
4. Constellation Error(EVM)@ target power					
1) 6Mbps	-	-	-5	dB	
2) 9Mbps	-	-	-8	dB	
3) 12Mbps	-	-	-10	dB	
4) 18Mbps	-	-	-13	dB	
5) 24Mbps	-	-	-16	dB	
6) 36Mbps	-	-	-19	dB	
7) 48Mbps	-	-	-22	dB	
8) 54Mbps	-	-31	-25	dB	
5. Frequency Error	-25	0	+25	ppm	
RX Characteristics	Min.	Typ.	Max.	Unit	
6. Minimum Input Level Sensitivity					
1) 6Mbps (PER \leq 10%)	-	-	-92	dBm	
2) 9Mbps (PER \leq 10%)	-	-	-91	dBm	
3) 12Mbps (PER \leq 10%)	-	-	-89	dBm	
4) 18Mbps (PER \leq 10%)	-	-	-87	dBm	
5) 24Mbps (PER \leq 10%)	-	-	-84	dBm	

6) 36Mbps (PER \leq 10%)	-	-	-81	dBm
7) 48Mbps (PER \leq 10%)	-	-	-78	dBm
8) 54Mbps (PER \leq 10%)	-	-76	-75	dBm
7. Maximum Input Level (PER \leq 10%)	-20	-10	-	dBm

3.3 802.11n HT20 模式

项目	规格			
协议	IEEE802.11n HT20 @ 2.4GHz			
模式	OFDM			
频段	CH1 to CH13			
速率 (MCS)	MCS0~15			
TX Characteristics	Min.	Typ.	Max.	Unit
2. Power Levels				
1) 17dBm Target@MCS0	15	17	19	dBm
2) 14dBm Target@MCS7	12	14	16	dBm
3. Spectrum Mask @target power				
1) at fc +/- 11MHz	-	-	-20	dBr
2) at fc +/- 20MHz	-	-	-28	dBr
3) at fc > +/-30MHz	-	-	-45	dBr
4. Constellation Error(EVM)@ target power				
1) MCS0	-	-	-5	dB
2) MCS1	-	-	-10	dB
3) MCS2	-	-	-13	dB
4) MCS3	-	-	-16	dB
5) MCS4	-	-	-19	dB
6) MCS5	-	-	-22	dB
7) MCS6	-	-	-25	dB
8) MCS7	-	-31	-28	dB
5. Frequency Error	-25	0	+25	ppm
RX Characteristics	Min.	Typ.	Max.	Unit
6. Minimum Input Level Sensitivity				
1) MCS0 (PER \leq 10%)	-	-	-88	dBm
2) MCS1 (PER \leq 10%)	-	-	-86	dBm
3) MCS2 (PER \leq 10%)	-	-	-84	dBm
4) MCS3 (PER \leq 10%)	-	-	-81	dBm
5) MCS4 (PER \leq 10%)	-	-	-78	dBm

6) MCS5 (PER \leq 10%)	-	-	-75	dBm
7) MCS6 (PER \leq 10%)	-	-	-72	dBm
8) MCS7 (PER \leq 10%)	-	-72	-70	dBm
7. Maximum Input Level (PER \leq 10%)	-20	-10	-	dBm

3.4 802.11n HT40 模式

项目	规格			
协议	IEEE802.11n HT40 @ 2.4GHz			
模式	OFDM			
频段	CH3 to CH11			
速率 (MCS)	MCS0~15			
TX Characteristics	Min.	Typ.	Max.	Unit
2. Power Levels (Calibrated)				
1) 16dBm Target @MCS0	14	16	18	dBm
2) 13dBm Target@MCS7	11	13	15	dBm
3. Spectrum Mask @14dBm				
1) at fc +/- 22MHz	-	-	-20	dBr
2) at fc +/- 40MHz	-	-	-28	dBr
3) at fc > +/-60MHz	-	-	-45	dBr
4. Constellation Error(EVM)@target power				
1) MCS0	-	-	-5	dB
2) MCS1	-	-	-10	dB
3) MCS2	-	-	-13	dB
4) MCS3	-	-	-16	dB
5) MCS4	-	-	-19	dB
6) MCS5	-	-	-22	dB
7) MCS6	-	-	-25	dB
8) MCS7	-	-30	-28	dB
5. Frequency Error	-25	0	+25	ppm
RX Characteristics	Min.	Typ.	Max.	Unit
6. Minimum Input Level Sensitivity				
1) MCS0 (PER \leq 10%)	-	-	-85	dBm
2) MCS1 (PER \leq 10%)	-	-	-83	dBm
3) MCS2 (PER \leq 10%)	-	-	-81	dBm
4) MCS3 (PER \leq 10%)	-	-	-78	dBm
5) MCS4 (PER \leq 10%)	-	-	-75	dBm

6) MCS5 (PER \leq 10%)	-	-	-72	dBm	
7) MCS6 (PER \leq 10%)	-	-	-69	dBm	
8) MCS7 (PER \leq 10%)	-	-69	-67	dBm	
7. Maximum Input Level (PER \leq 10%)	-20	-10	-	dBm	

想要了解更多深圳星恒讯科技的产品

请浏览我们的官网：www.movingcomm.com

阿里巴巴店铺：<https://movingcomm.1688.com/>

注意

您购买的产品、服务或特性等应受星恒讯公司商业合同和条款的约束，本档中描述的全部或部分产品、服务或特性可能不在您的购买或使用范围之内。除非合同另有约定，本公司对本档内容不做任何明示或默示的声明或保证。

由于产品版本升级或其他原因，本档内容会不定期进行更新。除非另有约定，本档仅作为使用指导，本档中的所有陈述、信息和建议不构成任何明示或暗示的担保。

提供的信息可随时更改而不事先通知。深圳星恒讯科技可以随时在不发通知的情况下修改产品生命周期、规格和产品说明。以上信息是按“原样”提供，深圳星恒讯科技对该信息的准确性、产品的特性、可用性、功能或列出产品的兼容性不做任何形式的声明或担保。请联系我们，了解关于上述特定产品或系统的更多信息。

Copyright © 2013-2026 Shenzhen MovingComm Technology Co., Ltd. All rights reserved.

深圳星恒讯科技有限公司

SHENZHEN MOVINGCOMM TECHNOLOGY CO., LTD.

地址：深圳市宝安区石岩街道水田社区长城路同富康

水田工业区 5 号楼 4 楼

邮编：518108

电话：86-755-23125215

传真：86-755-23125215-802

邮箱：sales@movingcomm.com

